



# Data Controller Console

## Standard Operating Procedure (SOP)

Information Sharing Agreement & Data Processing Contract  
management via the Data Controller Console (DCC)

June 2018

---

## Content

Purpose/Scope .....	4
Management of this SOP .....	4
Background.....	4
Applies to .....	9
DCC User Groups.....	10
Organisational Responsibilities .....	10
Starters and Leavers Policy .....	10
User Access Responsibilities .....	10
Training Responsibilities .....	11
Misuse and reporting defects within DCC.....	11
Training and Helpdesk service .....	11
Organisation Sign up Procedure & Verification.....	11
<i>Pre-requisites for Organisations using the DCC.....</i>	<i>11</i>
<i>Who needs to be registered to use the DCC.....</i>	<i>12</i>
<i>Log-on to Data Controller Console.....</i>	<i>12</i>
<i>Register Organisation .....</i>	<i>14</i>
<i>Approve / Reject Organisation's Submission.....</i>	<i>17</i>
<i>Update Organisation Profile .....</i>	<i>18</i>
<i>Add Information Sharing Agreement.....</i>	<i>19</i>
<i>Update Information Sharing Agreement.....</i>	<i>22</i>
<i>Complete Data Protection Impact Assessment (DPIA).....</i>	<i>23</i>
<i>Data Flows.....</i>	<i>26</i>
<i>Create a Data Processing Contract (DPC).....</i>	<i>27</i>
<i>Audit &amp; Reporting.....</i>	<i>32</i>
Export Reports.....	34
Data Flow.....	35
Other Related SOPs .....	36
References and Related Policies .....	36
Abbreviations / Definitions.....	37

Version number:	4.2
Effective date:	June 2018
Review date:	June 2018
Author:	T. Harvey
Reviewed by	A. Ogunyemi
Approved by:	S. Barnett

### Document Version History

Version number	Reason for Change
0.1	First draft
0.2	Updated draft
0.3	Updated draft
0.4	Comments from A. Ghosh incorporated
0.5	Updated draft
0.6	Comments from M. Hall incorporated
0.7	Minor updates plus addition of 'Invite org to join ISA' section
0.8	User Roles
0.9	Updated for DCC release V1.2
1.0	Final version for release following QA
1.1	Updated for DCC Release V1.3
1.2	Updated for DPIA & Local Authority Release V1.4
3.4	Updated for Enhanced Reporting, Data Links & RSU editing functionality Release V1.5
4.1	Update for GDPR and Public Facing Website Release 1.6
4.2	Update for Website change

**NOTE:**

Readers should be aware that paper copies of this document may not be the latest available version.

The latest version, which superseded all previous versions, will be made available via (insert local organisation link).

Those to whom this procedure applies are responsible for familiarising themselves periodically with the latest version.

## Purpose/Scope

The purpose of this Standard Operating Procedure (SOP) is to describe the process to be used by organisations for managing their Information Sharing Agreements (ISAs), Data Protection Impact Assessments (DPIA) and Data Processing Contracts (DPCs) and using the Data Controller Console application.

## Management of this SOP

This SOP should be reviewed annually by all organisations using the Data Controller Console (DCC), unless there is an identified need to review the SOP as a result of planned process changes or significant software update.

The owner of the SOP should follow the standard policy for updating/reviewing SOPs, ensuring that all necessary parties are involved in the review and the final updated version is made available to all staff via the intranet.

## Background

Many health and social care organisations (e.g. GPs, Acute Trusts, Local Authorities and Third Sectors) currently share information/data with each other to support effective care delivery, using Information Sharing Agreements (ISA's), resulting in many organisations having numerous discreet ISAs often sharing the same information to multiple recipients.

The process for managing these ISAs is time consuming and predominantly manual, with numerous paper documents that are hard to track for small and large organisations alike. ISA's also enable relationships between the organisations to develop on a local and regional level however the on-going management of the processes, the lag time to sign new agreements and the complex communication between multiple parties can slow information sharing down and make processes complex and unable to keep up with demand.

With this in mind the Healthy London Partnership in consultation with stakeholders across London have co-designed and developed the Data Controller Console (DCC). The DCC is an online application that enables organisations to have visibility and aid administration of their ISAs, reducing time and effort for organisations involved. It will provide a safe and secure mechanism for organisations to create and join sharing networks and rationalise/reduce the number of ISAs in use through awareness of all current ISAs; making best use of resource and moving towards the concept of a 'Club' by developing a 'trusted' data sharing environment for organisations across geographies and organisational boundaries.

The Beta Release of the DCC will provide the functionality to;

- Register an organisation
  - Record relevant information governance details
  - Identify key contacts for the organisation
  - Create User accounts

- Register ISAs
  - Record key ISA details
  - Identify ISA contacts
- Manage ISAs
  - Search for ISAs
  - Assign participating organisations to an ISA and invite them to 'join'
  - Manage requests

Enhancements in release 2 contain the following functionality:

- Audit & Reporting
  - Enables an organisation to view and extract information on ISAs that are associated with their organisation
- Organisation Tagging
  - Enables an organisation to add 'tag' groups based on the type of services the organisation provides, and the Boroughs these services are provided to
- Ability to search for an organisation by:
  - Services Provided and Boroughs Served
- Ability to delete a document uploaded in the ISA
- Ability to record an ISA that has no end date, but it must then have a review date

Enhancements in release 3 contain the following functionality:

- New Data Processing Contract (DPC) Tab
  - Create and a Data Processing Contract (4 Types):
    - Data Processing Contracts
    - Data Processing Deeds
    - Service Level Agreements
    - Service Contracts
- Add a processing organisation to your DPC
- Maintain a Data Processing Contract (DPC)
  - Edit & Update your organisations DPC
  - Upload New Version of a document in your organisations DPC
  - Delete a document from your organisations DPC
  - Export to Excel feature
  - Terminate a DPC
- Link DPCs to ISA's
  - Add a DPC to your own Organisations ISA (Add as a host of an ISA)
  - Add DPC to another organisations ISA (Add as a participant of an ISA)
  - Approve / reject another organisations DPC request
  - Delete your organisations DPC from your organisations ISA
  - Delete your organisations DPC from a participating ISA

Enhancements in release 4 contain the following functionality:

- Updates to ISA:
  - A new DPIA feature is added to OSU and AU roles.
  - User can filter ISA based on DPIA status:
    - Not Required – Historic ISA
    - Not Required – Checklist
    - Checklist Required
    - Required
    - Completed Digitally
    - Completed by Upload
  - RSU users have read only access to DPIA.
- Updates to Organisation Profile:
  - Organisation type – Local Authority is added
  - Contacts - Where organisation type is Local Authority user can select Role Category:
    - Adult Social Care
    - Children’s Social Care
  - Accreditation - 2 new options added (HSCN, OFSTEAD).
  - Organisation Tagging: Boroughs serviced – Instead of selecting Individual Boroughs if required User can select ‘All London Boroughs’

Enhancements in release 5 contain the following functionality:

- Data Flow (now Data Links) release
  - Data link function with mapping
  - Configurable data export capability
    - ISA
    - DPC
    - Organisation
  - New aggregated reporting
    - ISA Summary Report
    - DPC Summary Report
  - RSU Updates
    - RSU can fully manage organisations
    - RSU invite report
  - Email Updates
    - Sender’s name included in organisation invite email
    - From address now includes environment

Enhancements in release 6 contains the following functionality

- DPIA Mandatory for all ISAs
  - All ISAs must have a DPIA recorded
    - New ISAs cannot be saved without one
    - Existing ISAs cannot be updated without one
    - On opening an existing ISA that does not have all new mandatory data, user will be prompted.
  - Mandatory risk/issues entries – outlined in requirement below
  - Alert notification asking “do you wish to continue” for when a Data Controller wants to join an ISA with no DPIA
  - Remove option to mark DPIA as not necessary due to being historic ISA
- ISA Updates
  - Add in new dropdown under data which has following options:
    - Neither Children’s nor Adult’s Data
    - Children’s Data

- Adult's Data
  - Both Children's and Adult's Data
  - If user chooses to upload DPIA – still expose and collect this field.
  - Ability to add to strategic reporting, data flows and public website
  - Change other contacts in ISA creation to include third and fourth sector and 'Other' in drop down box.
- Publishing of ISAs
  - Add mandatory publish status dropdown
    - Not published
    - ISA published
  - Requires updates to export reports to reflect new field
  - Only ISAs with "ISA published" will be searchable on the public website
- DPO role on DPC
  - Add role of Data Processing Officer to DPC
  - DPO contact details for each organisation
  - Requires updates to export reports to reflect new fields.
- Organisational Role Updates
  - New role rules
    - Mandatory
      - Caldicott Guardian (as currently the case).
      - Data Protection Officer
    - Recommended
      - IG Manager/Lead
      - Privacy Officer
    - Optional
      - SIRO
      - Deputy SIRO
      - Clinical Safety Officer
    - Where recommended are NOT specified, a justification reason must be given
  - Other updates
    - Organisational contacts for an organisation will be able to have more than one role i.e. IG Manager/Lead can also be Data Protection Officer Recommended
    - Requires updates to the export reports to reflect multiple roles
- **ICO number mandatory**
  - Will be mandatory to complete on the popup that appears when adding an organisation
  - We will provide the ability to enter an ICO or search for one by organisation name. A valid entry must be selected from the results.
  - Once added, the ICO will not be editable by anyone other than a SysAdmin
  - For existing records with unknown ICOs Symphonic will manually map them to correct ICOs and introduce a temporary ICO for those which cannot be found. Org records with these temporary ICO will be shown in the summary section and will not be updatable until a real ICO has been allocated.
  - As selection of an ICO will always be through search (either by name or ICO) it will not be possible to allocate the same ICO to more than 1 organisation.
  - Quarterly updates of the ICO information means a very slim chance that an organisation registering may be entering a valid ICO but not finding it. In this case we can offer an email link for them to request their ICO details be added.





- Risk/Issue details
  - This will be present in a new tab “Risks/Issues” in ISA
    - ISA Risk RAG Level – dropdown
      - Red
      - Amber
      - Green
    - Table summarising existing Risks and Issues
  - Each entry will have
    - Date
    - Type - dropdown
      - Risk
      - Issue
    - Description – free text
    - Likelihood – dropdown
      - Rare
      - Unlikely
      - Possible
      - Likely
      - Almost Certain
    - Impact - dropdown
      - Negligible
      - Minor
      - Moderate
      - Major
      - Catastrophic
    - Owner – free text
    - Mitigating Details – free text
    - Status - dropdown
      - Open
      - Closed

For the purposes of this document, ‘users’ are those staff who as all/part of their role are required to access/use the DCC e.g. IG Manager, Caldicott Guardian etc.

## Applies to

All staff (managerial, clinical and administrative) who manage the information sharing governance processes or contribute to the process.

It is suggested that every organisation will have a minimum of two Organisation Super Users to facilitate appropriate management and access to the DCC.

The DCC has four levels of User Groups defined, see table below.

## DCC User Groups

Regional Super User (RSU)	<p>A key role of the Regional Super User is to 'approve' or 'reject' organisations who request to join the data controller console 'club'.</p> <p>This user has access to ALL functionality including modifying Organisation Profiles</p> <p><b>INCLUDING the ability to 'Approve/Reject' an organisation's application</b></p>
Organisation Super User (OSU)	<p>Key roles of the Organisation Super User are to manage their organisations ISAs (in conjunction with Active Users) and manage the creation of the User Accounts associated with their organisation</p> <p>This user has access to ALL functionality</p> <p><b>EXCLUDING the ability to 'Approve/Reject' an organisation's application</b></p>
Active User (AU)	<p>A Key role of the Active User is to manage the organisations ISAs on a day to day basis</p> <p>This user has access to functionality for: View all details and Create ISA, Update ISA, Remove ISA, Upload docs and approve or reject an invitation to participate in an ISA, excluding the ability to amend their Organisations details and create User Accounts</p>
View Only User (VOU)	This user has access to functionality for: View only

## Organisational Responsibilities

### Starters and Leavers Policy

It is the responsibility of the nominated organisation Super User to ensure that the 'users' of the DCC platform within their organisation is up to date i.e. users are added and removed in line with organisation's starters/leavers policy or a user has confirmed a change in role/responsibilities that impacts their user access profile. In the event of the OSU leaving the organisation before applying an update the RSU can update the Users if required.

### User Access Responsibilities

The beta release of the DCC will be available to access via the web. To assist in managing access to the application there will be a requirement for each organisation to manage a 'whitelist' of contacts i.e. domain details of each user. Access to the application will be restricted to those domains that are registered on the Whitelist. It is the responsibility of the organisation to keep this list accurate and up to date and the Supplier informed.

**The use of personal email accounts e.g. hotmail, gmail will not be supported/allowed.**

In the current Beta Release access to the DCC will be managed via;

- Access is only possible if email account domains on a managed 'whitelist' e.g. nhs.net, gov.uk (Only for Health and Care Organisations)
- Identifying named users from recognised organisations
- Restricting access to those with email address e.g. nhs.net, nhs.uk, .gov.uk
- Password protected log on

## Training Responsibilities

It is the responsibility of managers/supervisors that they and their staff, particularly new staff, have a full and comprehensive introduction to the DCC application, the supporting manual, videos, digital systems and processes. These can be found on the Healthy London Partnership (HLP) website, link: <https://www.healthylondon.org/>

It is each individual's responsibility to ensure that they maintain their knowledge and arrange appropriate updates and training as necessary.

## Misuse and reporting defects within DCC

The use of the DCC is for those persons who are required as part of their role to view/manage ISAs only.

It is the responsibility of each individual User to notify the nominated organisation lead of any defects/issues that they may witness as a result of using the DCC, giving comprehensive details/screenshot where possible.

## Training and Helpdesk service

**Point of Contact** - Please mention in the Subject line of the email that it relates to either

- DCC Training
- or
- DCC Technical

Hours of service: Monday to Friday, 09:00 to 17:00 only

Email contact: [England.DccSupport@nhs.net](mailto:England.DccSupport@nhs.net)

If your question is regarding:

- Training or how to use the DCC Portal, you will hear from us within one working day
- A specific technical issue in the system, we may need to investigate and get back to you within the next working day

## Organisation Sign up Procedure & Verification

### *Pre-requisites for Organisations using the DCC*

1. Organisations who wish to use the DCC application will need to be 'registered' via the online DCC process and must ensure that they are able to provide the following details;
  - a) ODS number
  - b) Organisation PostCode
  - c) IG Toolkit level 2 to satisfactory or above
    - a. If you do not meet level 2 for all standards, you can provide an action plan to cover appropriate areas
  - d) ICO registration number
  - e) Contacts within the organisation:
    - i. For general communication
    - ii. For communication related to an specific ISA
    - iii. For those individuals that require access to use the DCC
2. Registration may be initiated by:
  - a. The organisation itself, by completing their registration details

- i. With the application subsequently approved / rejected by the regional super user
  - b. A regional super user registering the organisation i.e. the registration details are completed on another organisations' behalf
    - i. With application details sent to the organisation to confirm
    - ii. Once the organisation confirms the application, it is reviewed and subsequently approved / rejected by the regional super user
3. Once an organisation is successfully registered, they will be able to add their information sharing agreements (ISAs) details.

### *Who needs to be registered to use the DCC*

<b>User</b>	<b>Example staff role</b>
Regional Super User (RSU)	At a level that embraces multiple individual entities/organisations e.g. CCG <ul style="list-style-type: none"> <li>• IG Manager</li> <li>• Senior Information Risk Owner [SIRO]</li> </ul>
Organisation Super User (OSU)	At individual entity/organisation level e.g. Acute Trust, GP Practice <ul style="list-style-type: none"> <li>• IG Manager</li> <li>• Senior Information Risk Owner [SIRO]</li> <li>• Caldicott Guardian</li> </ul>
Active User (AU)	Any user who needs to manage ISAs on a day to day basis <ul style="list-style-type: none"> <li>• IG Manager</li> <li>• Caldicott Guardian</li> </ul>
View Only User (VOU)	<ul style="list-style-type: none"> <li>• Data Controller</li> <li>• Caldicott Guardian</li> </ul>

### *Log-on to Data Controller Console*

#### **Log-on**

<b>Step</b>	<b>Task</b>	<b>Role(s) responsible</b>
1	Access DCC via username and password	Users

### Log-on: Exceptions

Step Ref	Exceptions	Actions
1	Unable to log-on (forgotten password)	Select 'Forgot your password?' link and enter the registered email address and await response
1	Unable to log-on as 'locked out' due to multiple log-on attempts	Select 'Forgot your password?' link and enter email address and await response. <b>N.B.</b> A link to reset your password will be sent by email from <a href="mailto:no-reply@datacontroller.london">no-reply@datacontroller.london</a> If you have rules set up to send all these DCC notifications into a designated e-mail folder, please check this folder for the e-mail and re-set your password within 15 minutes of receiving the e-mail.
1	Unable to log-on (system down; planned/unplanned downtime)	Contact your regional Super User or email <a href="mailto:england.dccsupport@nhs.net">england.dccsupport@nhs.net</a> to seek information
1	User is assigned as a regional super user but also needs to be assigned as an organisational super user	Refer to 'Manage User Accounts' in the User Guide
1	User is assigned as an organisational super user but also wishes to be assigned as a regional super user	Contact the area Regional Super User and confirm that they will support your application to be assigned a RSU role.  Complete DCC feedback form (General Comment option) and document request, identifying the name of the supporting RSU

## Register Organisation

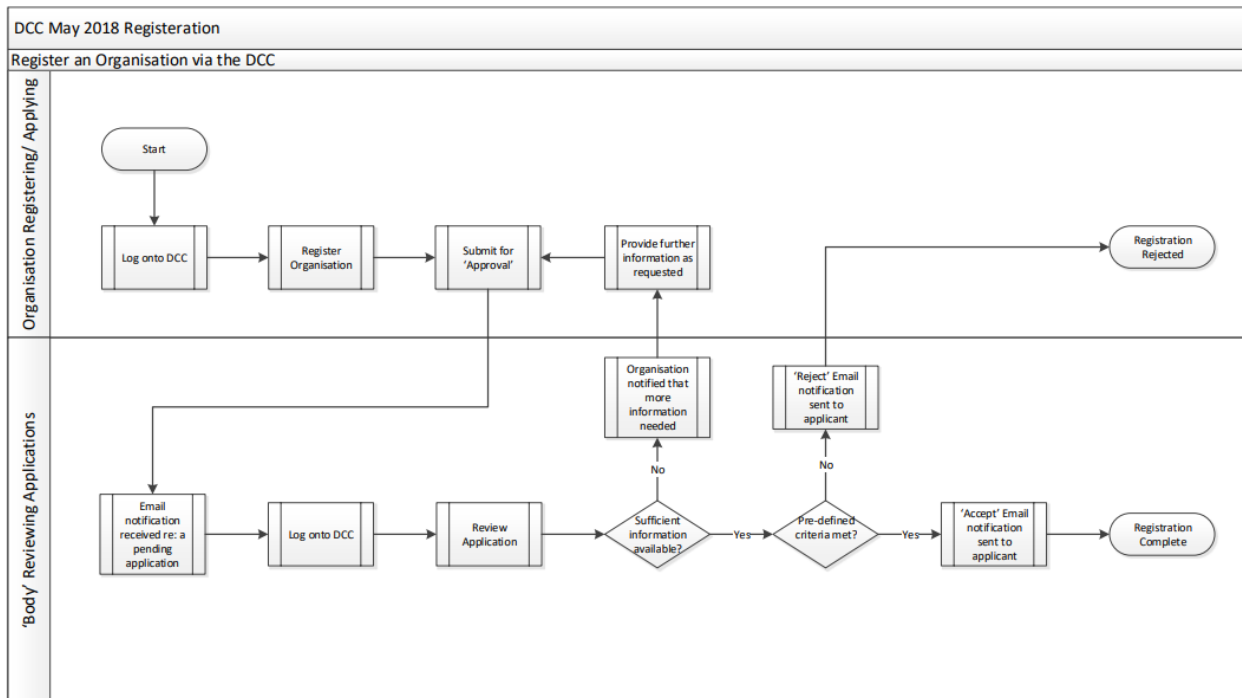

### Preparation

Step	Task	Role(s) responsible
1	Have organisation details available; <ul style="list-style-type: none"> <li>ICO Registration Number</li> <li>ICO Expiry Date</li> <li>ODS Code</li> <li>Organisation Name</li> <li>Organisation Postcode</li> <li>Organisation Type (NHS/Local Authority/Third Party)</li> <li>Provide Direct Care (Y/N)</li> <li>Organisation Region (NWL, NEL, NCL, SWL, SEL)</li> <li>Organisation Tagging (Type of Services provided &amp; Boroughs Serviced by the organisation)</li> </ul>	Super User
2	Have list of organisation contacts, <ul style="list-style-type: none"> <li>one of whom <b>MUST</b> be the designated Caldicott Guardian</li> <li>one must have the Organisation Super User Role allocated</li> <li>A Data Protection Officer <b>MUST</b> be specified</li> <li>Privacy Officer and IG Manager/Lead are recommended                             <ul style="list-style-type: none"> <li>If not specified then a reason must be given</li> </ul> </li> </ul> <p><b>Note:</b> registration cannot be submitted without this information.</p> <ul style="list-style-type: none"> <li>First name</li> <li>Last name</li> <li>Role</li> </ul>	Super User

	<ul style="list-style-type: none"> <li>○ Local Authorities may enter:</li> <li>○ Caldicott Guardian (Adult Social Care) &amp;</li> <li>○ Caldicott Guardian (Children's Social Care)</li> <li>● (role other details)</li> <li>● Email</li> <li>● Phone</li> <li>● Mobile</li> <li>● Create User Account (Y/N)</li> </ul>	
3	Know file location of relevant documents that may be uploaded to support registration process (optional)	Super User

### Register Organisation

Step	Task	Role(s) responsible
1	Access DCC and complete organisation profile, including organisation contacts, identifying those who need user accounts and complete the Organisation Tagging	Super User
2	Application is submitted	Super User

### Register New Organisation: Exceptions

Step Ref	Exceptions	Actions
2	Registered Organisation indicates that they haven't received the Invitation email	Access the DCC 'Organisations' tab. Ensure that the organisations status column reads 'Invited' (This feature doesn't work for Pending or Accepted, which means that one person from the organisation has already accepted the invitation). Select the ISA you are hosting in the 'Invited' status. Select the Resend Invite button adjacent to the organisations contact name.
2	Notification received that registration submission 'rejected'	Contact <insert contact details> to discuss
2	Notification received requesting 'more information required'	Access DCC and complete information as requested
2	Application submitted in error (no ISAs added)	Contact <insert contact details> to request application is removed/deleted
2	Application submitted in error (and ISAs added)	Contact <insert contact details> to request application is removed/deleted

---

2	Registered organisations have merged (and ISAs are in place)	Contact <insert contact details> (supplier) to request merger of organisations
---	--	--



## User Accounts

Step	Task	Role(s) responsible
1	Notification received: new user account created and login required to update password	User

## User Accounts: Exceptions

Step Ref	Exceptions	Actions
1	No user account notification received from <a href="mailto:no-reply@datacontroller.london">no-reply@datacontroller.london</a>	Contact <insert organisation contact details> the Organisation Super User and check if you have been identified as a 'user' and confirm contact details are correct
1	Unable to perform actions needed within the DCC	Contact <insert organisation contact details> the Organisation Super User to understand the level of access granted and request a change to level of access e.g. 'view only' to 'active'
1	User unable to change account password	Contact <insert organisation contact details> for assistance
1	User account no longer required	Refer to local Starters & Leavers Policy or contact <insert organisation contact details>

## *Approve / Reject Organisation's Submission*

### Approve/Reject Organisation's submission

Step	Task	Role(s) responsible
1	Access DCC and review submission from organisation	RSU
2	'Approve' submission	RSU

### Approve/Reject Organisation's submission: Exceptions

Step Ref	Exceptions	Actions
2	Insufficient information in submission to support approval	Choose 'Request more information' option detailing the information required AND contact the submitting organisation in person to discuss
2	Supporting information does not meet the acceptance criteria	Choose 'Reject' option AND contact the submitting organisation in person to discuss

### Update Organisation Profile

#### Update Organisation Profile

Step Ref	Task	Role(s) responsible
1	<p>Access DCC, from the Organisations Tab, select 'Register New Organisation' and complete the following details</p> <ul style="list-style-type: none"> <li>• Organisation Codes (ICO / ODS)</li> <li>• Organisation Profile details</li> <li>• Organisation contacts, identifying those who need user accounts and complete.</li> <li>• Organisation Tagging <ul style="list-style-type: none"> <li>○ Services Provided</li> <li>○ Boroughs Serviced (option for All London Boroughs)</li> </ul> </li> <li>• Accreditations and upload related documents e.g. <ul style="list-style-type: none"> <li>HSCN - Allows you to enter a date</li> <li>OFSTEAD - Inspection Date, Add Rating and Notes</li> <li>Other information</li> </ul> </li> </ul> <p>N.B. If a Local Authority there is the option in Contacts to add two Role Categories:</p> <p>Caldicott Guardian (Adult Social Care)</p> <p>Caldicott Guardian (Children's Social Care)</p>	RSU/OSU
2	Update saved	RSU/OSU

### Update Organisation Profile: Exceptions

Step Ref	Exceptions	Actions
1	Unable to update/edit/save organisation details	Contact <insert details> to understand level of access granted and request change to level of access if appropriate

### Add Information Sharing Agreement

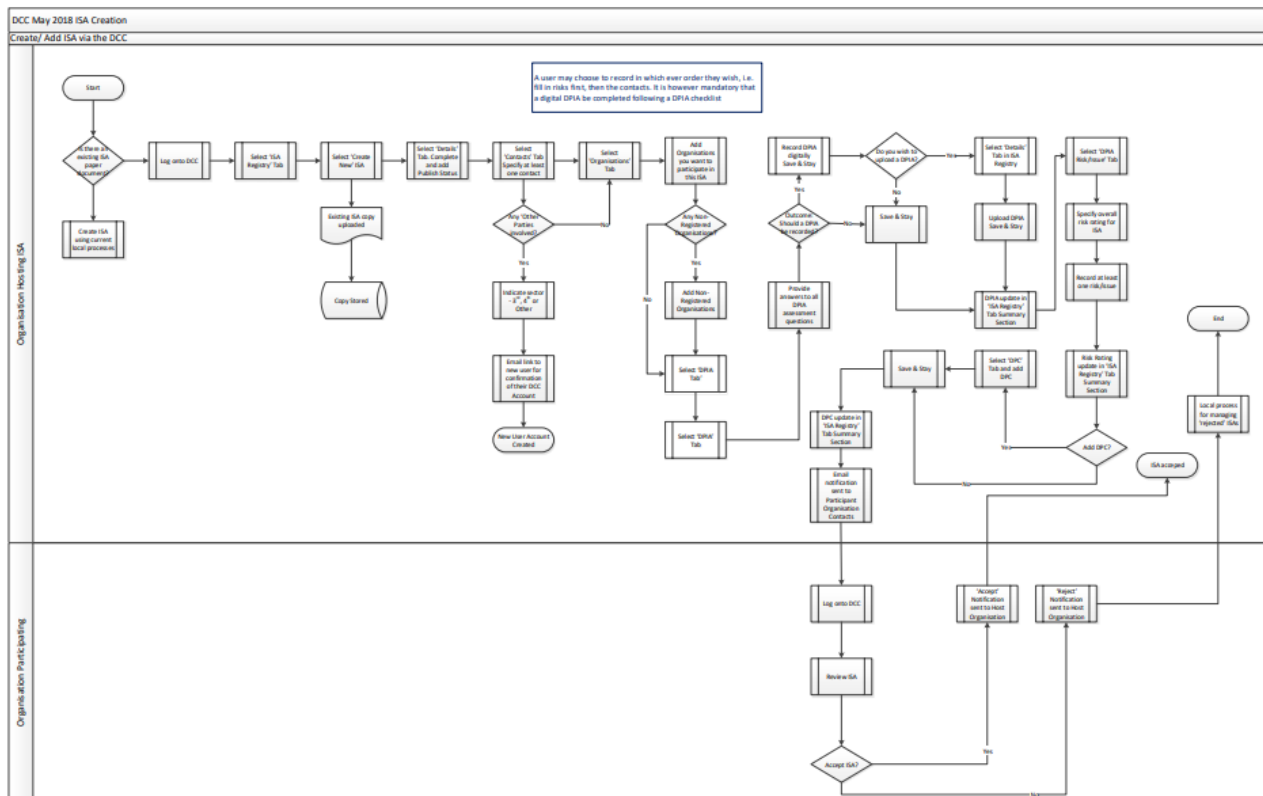

### ISA Preparation

Step	Task	Role(s) responsible
1	Have email notification that the organisation application complete i.e. registration successful	OSU
2	Ensure all copies of ISAs are available on local drive	OSU/AU
3	Have following ISA details readily available; <ul style="list-style-type: none"> <li>• Agreement Title</li> <li>• Description</li> <li>• Valid From</li> <li>• Valid To (if on-going ISA, then ISA review date)</li> <li>• Version</li> </ul>	OSU/AU

	<ul style="list-style-type: none"> <li>Owner/Custodian</li> </ul>	
4	<p>Have list of organisation contacts, ideally at least two contacts per Agreement, one of whom <b>MUST</b> be the Caldicott Guardian;</p> <ul style="list-style-type: none"> <li>First name</li> <li>Last name</li> <li>Role</li> <li>(role other details)</li> <li>Email</li> <li>Phone</li> <li>Mobile</li> <li>Notify of updates?</li> </ul>	OSU/AU
5	<p>Have other ISA related information available;</p> <ul style="list-style-type: none"> <li>Organisations involved/participating in the agreement</li> <li>Other parties involved (Data Processor / Sub Data Processor)</li> <li>Data relates to direct/indirect care</li> <li>Services provided</li> </ul>	OSU/AU

### ISA Preparation: Exceptions

Step Ref	Exception	Action
1	No registration notification received	<p>Check registration submitted online</p> <p>Contact &lt; insert details &gt; to confirm receipt of submission and that contact details are correct</p>
2	ISA available as paper documents only	Scan and upload paper only copies to local drive
3	ISA 'Valid to' date exceeded	Contact Caldicott Guardian/Information Governance group to notify of expiry date (there may be cases where ISA has expired and the ISA has been superseded). If the ISA has no expiry date, then obtain a review date.
4	Caldicott Guardian not identified on agreement	Confirm CG contact for the ISA
4	Caldicott Guardian (CG) details not available	Obtain CG details as ISA addition cannot be completed without them

### Add ISA

Step	Task	Role(s) responsible

1	Access DCC and go to 'ISA – Registry' to <b>Create new ISA</b> including Details, Contacts, Organisation and Non-Registered Organisations and DPIA Tabs. DPCs Tab optional	RSU, OSU, AU
1	Upload new Documents:  Title (If not entered will take document name as Title)  Description (Mandatory)  Category (Mandatory)	
2	'Save' details	RSU, OSU, AU

### Add ISA: Exceptions

Ref to Step	Exceptions	Actions
2	ISA added in error	Select the <b>Delete</b> button adjacent to the uploaded document in the 'Details' tab. Documents deleted in error can be restored by contacting <a href="mailto:england.dccsupport@nhs.net">england.dccsupport@nhs.net</a>
2	ISA contact details are incorrect	Access DCC and update/edit details
2	ISA organisation identified as participating are incorrect	Access DCC and update/edit details
2	ISA data details are incorrect	Access DCC and update/edit details

### Invite Organisation to join ISA

Step	Task	Role(s) responsible
1	Access DCC and go to 'ISA – Registry', select Organisations tab	RSU, OSU, AU
2	Select the organisation you would like to be involved in the particular ISA and 'add selected'  Select the <b>Select organisation</b> button to search for the organisation(s) you would like to involve in this particular ISA by using their Name, Region, ODS code, Type of organisation or the Services provided or Boroughs serviced tags. Place a tick in the checkbox(s) then click the <b>Select</b> button to invite the organisation(s) to the ISA	RSU, OSU, AU

### Invite Organisation to join ISA: Exceptions

Step Ref	Exceptions	Actions
1	Unable to find an Organisation to invite to an ISA	Select the 'Non-Registered Organisations' tab and search for the organisation using Name, ICO number or ODS code

### Update Information Sharing Agreement

#### Update/Delete ISA

Step	Task	Role(s) responsible
1	Access DCC and update/edit ISA and give reason for update	RSU/OSU/AU
2	Access DCC an delete ISA and give reason for the deletion	
3	Update saved	RSU/OSU/AU

#### Update/Delete ISA: Exceptions

Step Ref	Exception	Action
1	Unable to update/edit/delete and save ISA details	Contact organisation super user to understand level of access granted and request change to level of access e.g. 'view only' to 'active' if appropriate

## Complete Data Protection Impact Assessment (DPIA)

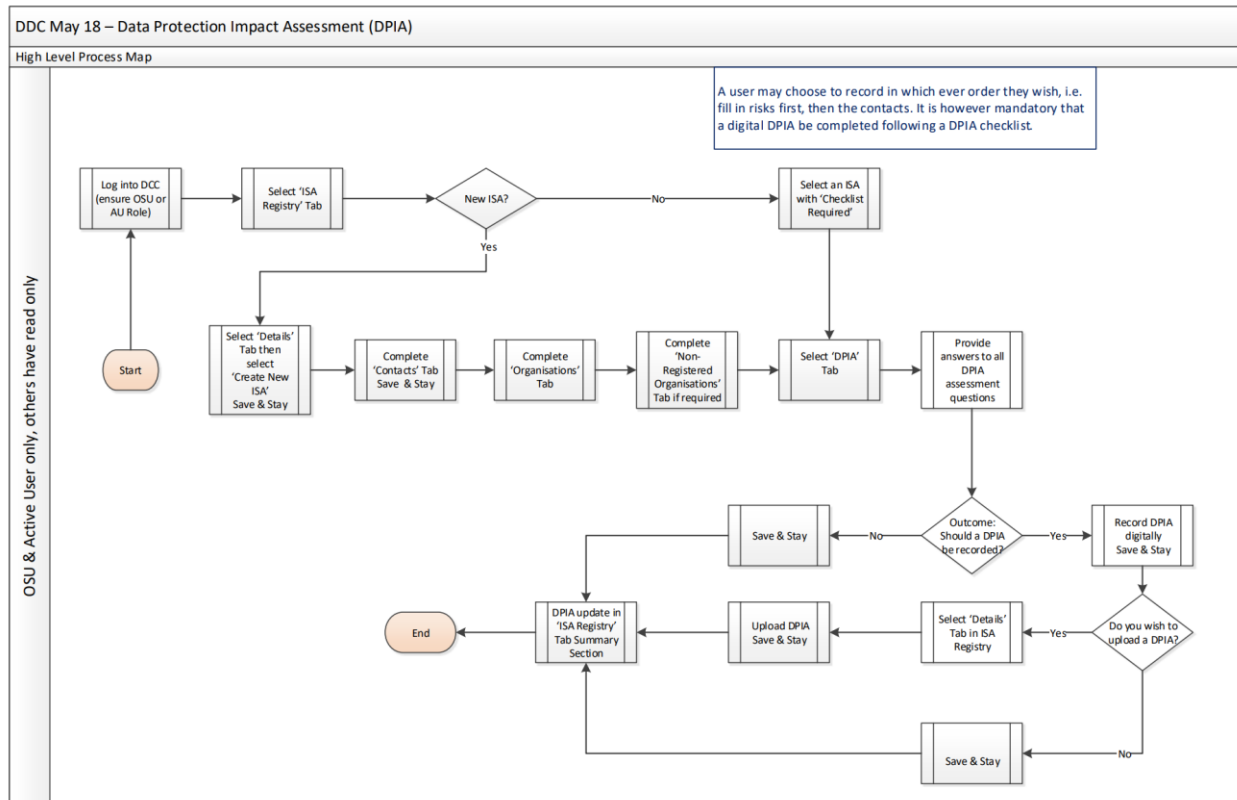

### DPIA Preparation

Step	Task	Role(s) responsible
1	Ensure to have the 11 DPIA Checklist questions to hand	OSU, AU
4	Have the following 11 checklist answers readily available for Digital completion; <ol style="list-style-type: none"> <li>1) Type of information are you sharing</li> <li>2) New data?</li> <li>3) What is the purpose?</li> <li>4) Does the information sharing introduce new or additional technologies?</li> <li>5) Does information sharing about the individual raise privacy concerns?</li> <li>6) Does the information sharing involve you using new technology which might be perceived as being intrusive? For example, the use of data to make a decision about care that's automated?</li> <li>7) Will information about individuals be disclosed to organisations or people who have not previously had routine access to the information?</li> <li>8) Will the project require you to contact individuals in ways which they may find intrusive?</li> <li>9) Will 3 or more organisations be involved in sharing the information?</li> </ol>	OSU, AU

	<p>10) Will the information sharing involve new or significantly changed consolidation, inter-linking, cross referencing or matching of personal data from multiple sources?</p> <p>11) Is any adult or children data involved?</p>	
5	<p>Have following DPIA answers readily available for Digital completion;</p> <ul style="list-style-type: none"> <li>• People <ul style="list-style-type: none"> <li>○ Are there privacy notices to enable information sharing? <ul style="list-style-type: none"> <li>▪ If Yes, select Location of Privacy Notices</li> </ul> </li> <li>○ Do you have a defined subject access request process? <ul style="list-style-type: none"> <li>▪ If yes, provide Link details</li> </ul> </li> </ul> </li> <li>• Process <ul style="list-style-type: none"> <li>○ What is the lawful basis for processing information? <ul style="list-style-type: none"> <li>▪ See pick list</li> </ul> </li> <li>○ Are the new purposes for processing information stated in the current ISA likely to be identified in the future?</li> <li>○ Have all organisations sharing or consuming information met the minimum IG Toolkit Level 2?</li> <li>○ Will any information stated in the ISA be transferred outside EEA?</li> </ul> </li> <li>• Technology <ul style="list-style-type: none"> <li>○ If required, do you or any parties subject to the ISA have the means to make changes to the data?</li> <li>○ Is there a section within the ISA that covers Data Quality? <ul style="list-style-type: none"> <li>▪ If Yes, specify section from the ISA?</li> </ul> </li> <li>○ Does the organisation and agreement comply with records management code? <ul style="list-style-type: none"> <li>▪ If Yes, provide Link details</li> </ul> </li> <li>○ Is your information security proportional to the sensitivity of the data being transferred?</li> </ul> </li> <li>• Data <ul style="list-style-type: none"> <li>○ Select the data covered? (Pick list)</li> </ul> </li> </ul>	OSU, AU
6	Decide if a print out of the Digitally completed ISA / DPIA will be required?	OSU, AU

### DPIA Preparation: Exceptions

Step Ref	Exception	Action
1	Unable to enter a valid DPIA Date	DPIA Date cannot be a future date, ensure to enter a current date



### Complete DPIA Checklist and DPIA

Step	Task	Role(s) responsible
1	<p>Access DCC and go to ISA Registry Tab</p> <p>Either:</p> <ul style="list-style-type: none"> <li>• Select an existing ISA which has 'Required' in the DPIA Column or</li> <li>• Create a New ISA and complete the Details and Contact Tabs as a minimum before selecting the DPIA Tab.</li> </ul>	OSU, AU
2	Complete the 11 Checklist questions as per DPIA Preparation section above.	OSU, AU
3	<p>Complete DPIA</p> <ul style="list-style-type: none"> <li>• Complete Digitally via the DPIA Tab</li> <li>• Upload DPIA document via the ISA Registry Tab, Details Tab (as you did to upload the ISA).</li> </ul>	OSU, AU
4	'Save' details	OSU, AU
5	Print DPIA via browser if required	OSU, AU

### Complete DPIA Checklist & DPIA: Exceptions

Ref to Step	Exceptions	Actions
1	User Roles	RSU & VO Roles will only have read only access to DPIAs
3	Digital DPIA details are incorrect	Access DCC and update the DPIA details digitally then save and stay
3	DPIA document uploaded in error	Select the <b>Delete</b> button adjacent to the uploaded document in the 'Details' tab. Documents deleted in error can be restored by contacting <insert contact details> (ISA host)

### DPIA Risks and Issues

#### Complete the DPIA Risks and Issues detail

Insert Process map

### Complete DPIA Risks and Issues

Step	Task	Role(s) responsible
1	<p>Access DCC and go to ISA Registry Tab</p> <p>Either:</p> <ul style="list-style-type: none"> <li>Select an existing ISA which has 'Unknown' in the DPIA Risks/Issues Column or</li> <li>Create a New ISA and complete the Details and Contact Tabs as a minimum before selecting the DPIA Risks/Issues Tab.</li> </ul>	OSU, AU
2	<p>Complete the overall risk for the ISA</p> <ul style="list-style-type: none"> <li>Red</li> <li>Amber</li> <li>Green</li> </ul>	OSU, AU
3	<p>Complete at least one risk/issue</p> <ul style="list-style-type: none"> <li>Select Add New Record</li> <li>Complete Date,</li> <li>Type,</li> <li>Status,</li> <li>Description</li> <li>Owner</li> </ul>	OSU, AU

	<ul style="list-style-type: none"> <li>• Mitigating Details</li> <li>• For Risks complete additional fields             <ul style="list-style-type: none"> <li>○ Likelihood</li> <li>○ Impact</li> </ul> </li> </ul>	
4	'Update' details	OSU, AU

### Create a Data Processing Contract (DPC)

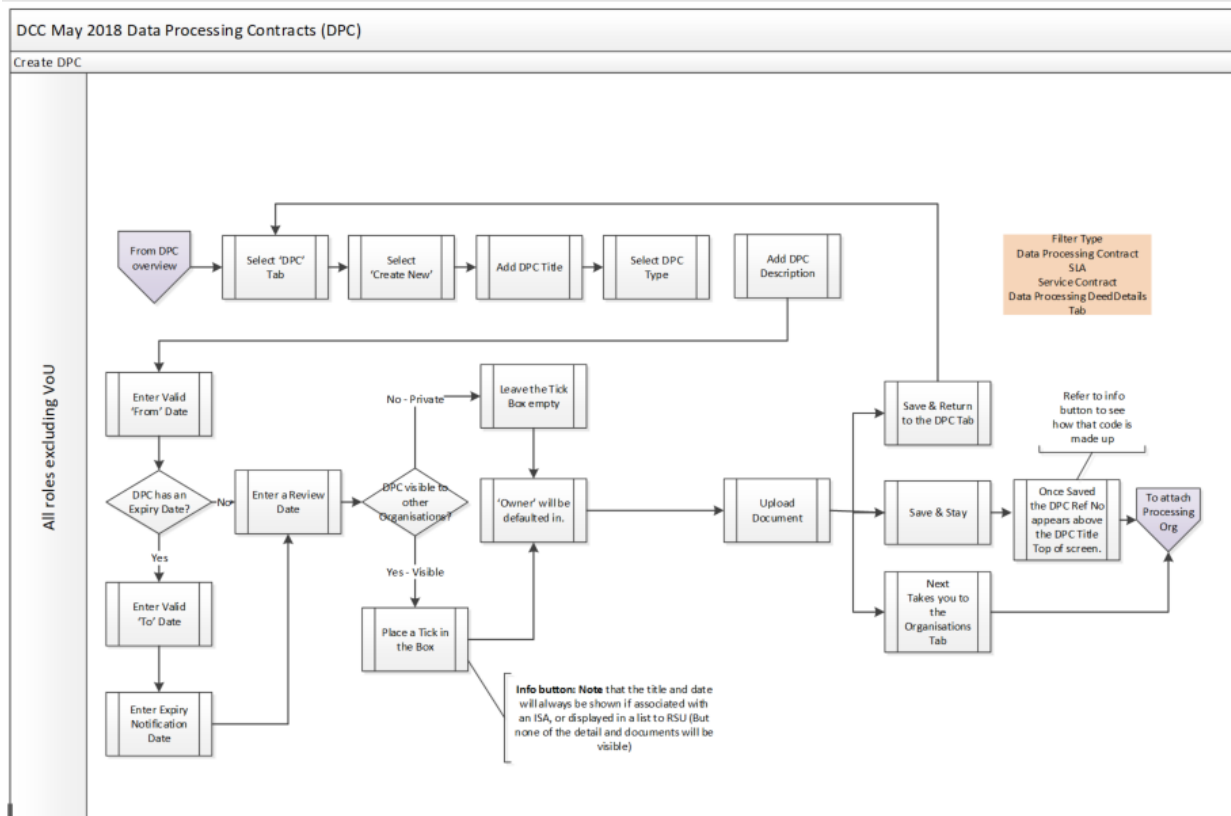

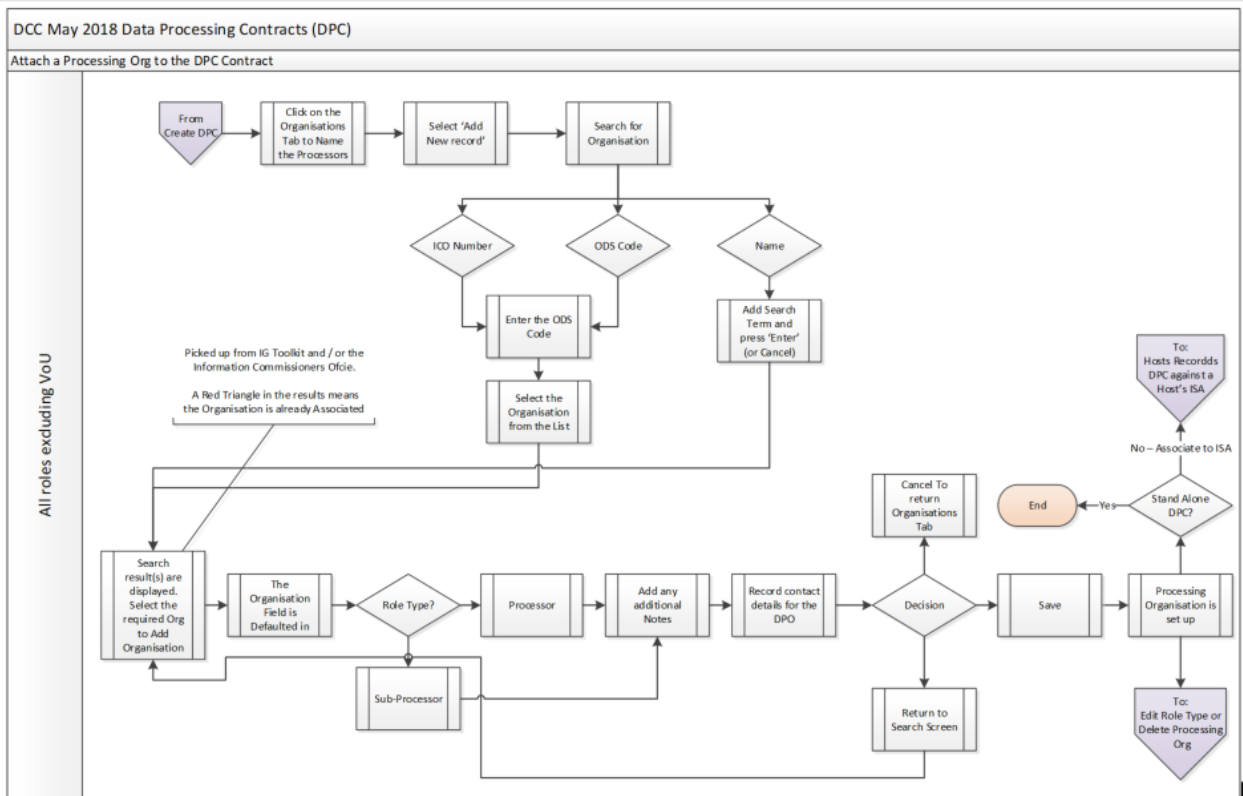

### DPC Preparation

Step	Task	Role(s) responsible
1	Ensure all copies of DPCs are available on local drive	RSU, OSU, AU
2	Have following DPC details readily available; <ul style="list-style-type: none"> <li>• DPC Title</li> <li>• Description</li> <li>• Type</li> <li>• Valid From</li> <li>• Valid To (if on-going DPC, then DPC review date)</li> <li>• Version</li> <li>• If you wish the DPC to be 'Visible to others'</li> </ul>	RSU, OSU, AU
3	Have list of processing organisations Names, ICO Registration Numbers or ODS codes.  Note: Important to note that the DPC may be between One data controller and several data processors, Several data controllers and several data processors, Several data controllers and one data processor.	RSU, OSU, AU

### DPC Preparation: Exceptions

Step Ref	Exception	Action
1	DPC available as paper documents only	Scan and upload paper only copies to local drive
2	DPC 'Valid to' date exceeded	Contact Caldicott Guardian/Information Governance group to notify of expiry date (there may be cases where DPC has expired and the DPC has been superseded). If the DPC has no expiry date, then obtain a review date.

### Create a DPC

Step	Task	Role(s) responsible
1	Access DCC and go to 'DPC' tab to <b>Create new DPC</b> including details and processing organisations	RSU, OSU, AU
2	'Save' details	RSU, OSU, AU

### Create a DPC: Exceptions

Ref to Step	Exceptions	Actions
1	DPC document uploaded in error	Select the <b>Delete</b> button adjacent to the uploaded document in the 'Details' tab. Documents deleted in error can be restored by contacting <b>&lt;insert contact details&gt; (DPC host)</b>
1	DPC details are incorrect	Access DCC and update/edit details
1	DPC processing organisation identified as incorrect	Access DCC and update/edit details
1	DPC data details are incorrect	Access DCC and update/edit details

### Attaching DPC to hosted ISA

Step	Task	Role(s) responsible
1	Access DCC and go to 'ISA-Registry' tab to open the ISA that the DPC will be associated with.	RSU, OSU, AU
2	Navigate to the 'DPCs' tab within the ISA and search for and attach your organisations DPC.	RSU, OSU, AU
3	'Save' the ISA.	RSU, OSU, AU

### Attaching DPC to hosted ISA: Exceptions

Ref to Step	Exceptions	Actions
2	DPC added in error	Select the <b>Delete</b> button adjacent to the uploaded DPC document in the 'DPCs' tab. Documents deleted in error can be restored by contacting <b>&lt;insert contact details&gt; (supplier)</b>
2	DPC organisation identified as participating are incorrect	Access DCC and update/edit details
2	DPC data details are incorrect	Access DCC and update/edit details

### Attaching DPC to an ISA as a participant

Step	Task	Role(s) responsible
1	Access DCC and ensure that your organisation has <b>Accepted</b> the invitation to participate in the ISA and it is visible by your organisation.	RSU, OSU, AU
2	Access DCC and go to 'DPCs' tab in the participating ISA. Search for and Add your organisations DPC.	RSU, OSU, AU
3	'Save' details.	RSU, OSU, AU
4	The DPC will be attached once the host organisation of that ISA has accepted your request to attach your DPC.	RSU, OSU, AU

### Attaching DPC to ISA as a participant: Exceptions

Ref to Step	Exceptions	Actions
2	DPC added in error	Select the <b>Delete</b> button adjacent to the uploaded document in the 'Details' tab. Documents deleted in error can be restored by contacting <b>&lt;insert contact details&gt; (supplier)</b>
2	Not able to view other DPCs / a DPC has a pad lock symbol.	This DPC is marked as private and you will need to contact the organisation hosting the ISA to request further information.
2	DPC organisation identified as participating are incorrect.	Access DCC and update/edit details
2	DPC data details are incorrect.	Access DCC and update/edit details

*Audit & Reporting*

**Housekeeping Report**

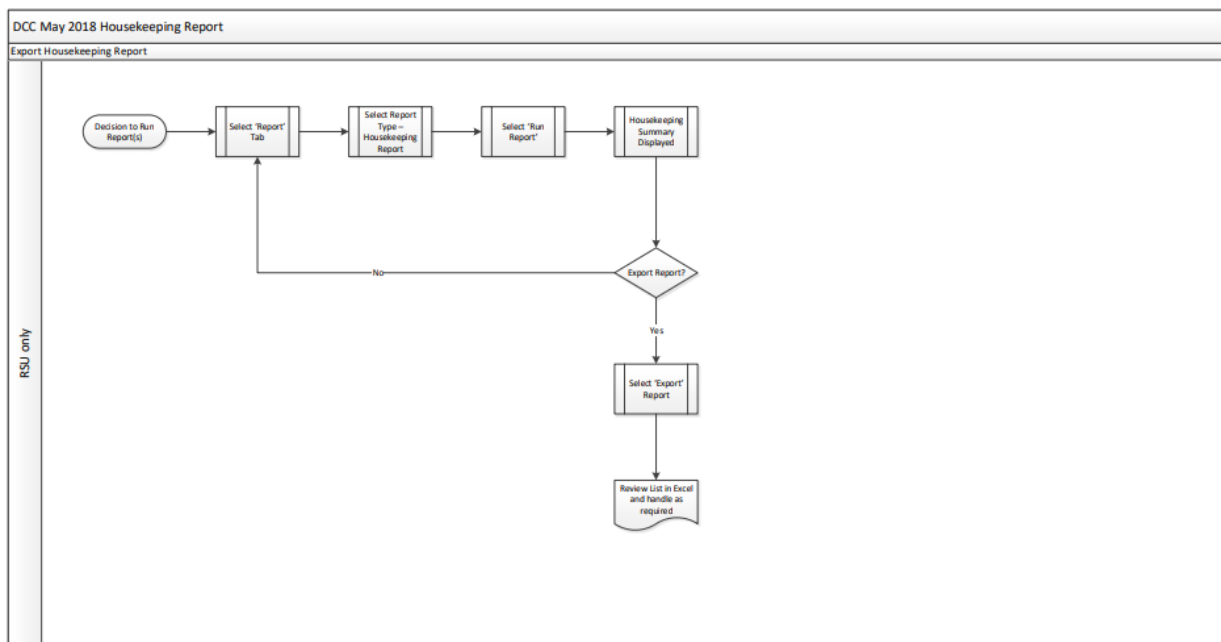

Step	Task	Role(s) responsible
1	Access DCC and select the 'Reports' tab	RSU
2	Select the <b>Report Type</b> drop-down and select the House Keeping Report	RSU
3	View data table or select the [Export Report] link to download the report into an excel spread sheet	RSU

**Housekeeping Report: Exceptions**

Step Ref	Exception	Action
3	Unable to view or download the Housekeeping report	Use the DCC <b>Leave Feedback</b> option from the banner bar to report the fault
1	Unable to access the functionality	Contact organisation super user to understand level of access granted and request change to level of access e.g. 'view only' to 'active' if appropriate



### Non-Registered Organisations Report

Step	Task	Role(s) responsible
1	Access DCC and select the 'Reports' tab	RSU/OSU/AU/VOU
2	Select the <b>Report Type</b> drop-down and select the Non-Registered Organisations Report	RSU/OSU/AU/VOU
3	View the data table or select the [Export Report] link to download the report into an excel spread sheet	RSU/OSU/AU/VOU

### Non-Registered Organisations Report: Exceptions

Step Ref	Exception	Action
1	Unable to view or download the Non-Registered Organisation report	Use the DCC <b>Leave Feedback</b> option from the banner bar to report the fault
1	Unable to access the functionality	Contact organisation super user to understand level of access granted and request change to level of access e.g. 'view only' to 'active' if appropriate

### Summary Report

Step	Task	Role(s) responsible
1	Access DCC and select the 'Reports' tab	RSU/OSU/AU/VOU
2	Select the <b>Report Type</b> drop-down and select the Summary Report	RSU/OSU/AU/VOU
3	View the data table or select the [Export Report] link to download the report into an excel spread sheet	RSU/OSU/AU/VOU

### Summary Report: Exceptions

Step Ref	Exception	Action
1	Unable to view or download the Summary report	Use the DCC <b>Leave Feedback</b> option from the banner bar to report the fault
1	Unable to access the functionality	Contact organisation super user to understand level of access granted and request change to level of access e.g. 'view only' to 'active' if appropriate

## Export Reports

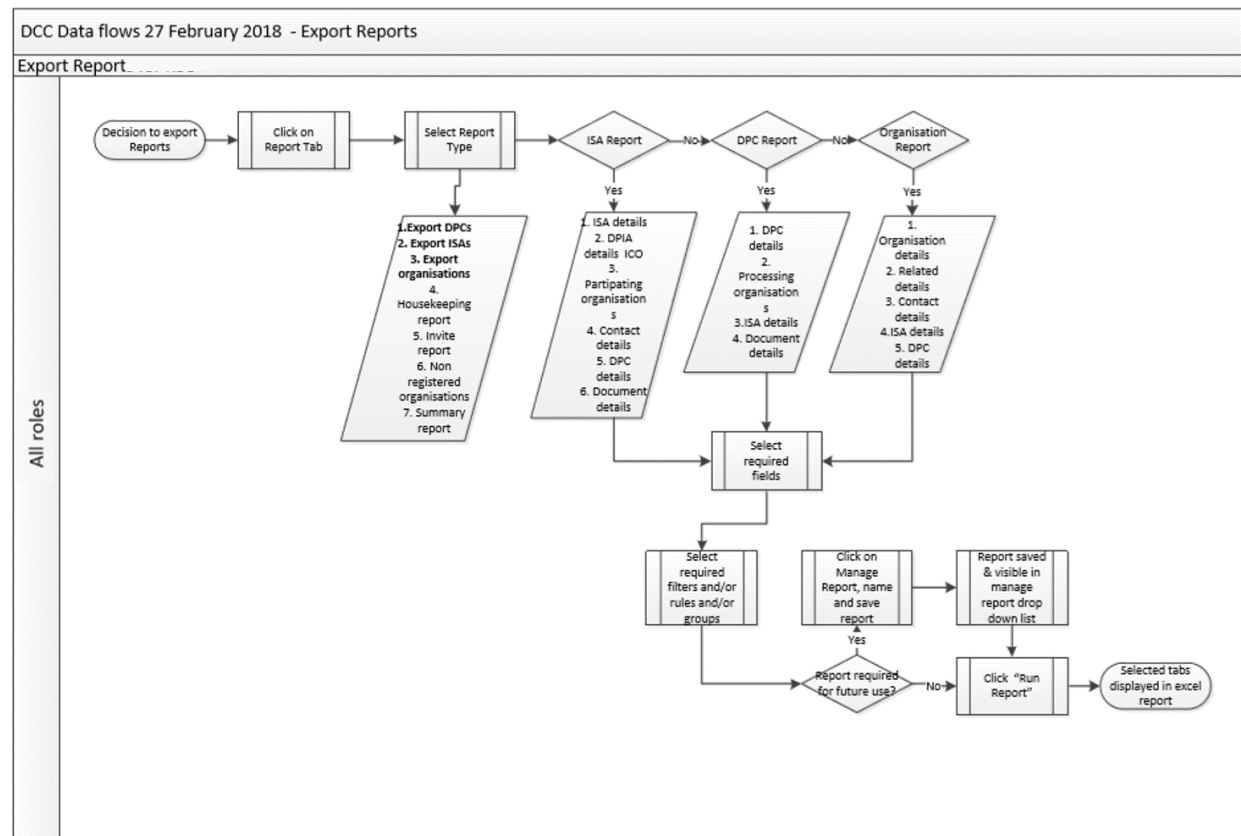

Step	Task	Role(s) responsible
1	Access Report tab	RSU/OSU/AU/VOU
2	Select Report Type	RSU/OSU/AU/VOU
3	Select required fields	RSU/OSU/AU/VOU
4	Select required Filters and/or Rules and/or Groups	RSU/OSU/AU/VOU
5	Select Manage Reports	RSU/OSU/AU/VOU
6	Name Report	RSU/OSU/AU/VOU
7	Select Run Report	RSU/OSU/AU/VOU
8	Selected Fields displayed in Excel	RSU/OSU/AU/VOU
9	Re-run Report by Selecting Report name from drop down	RSU/OSU/AU/VOU
10	Select Run Report	RSU/OSU/AU/VOU

## Data Flow

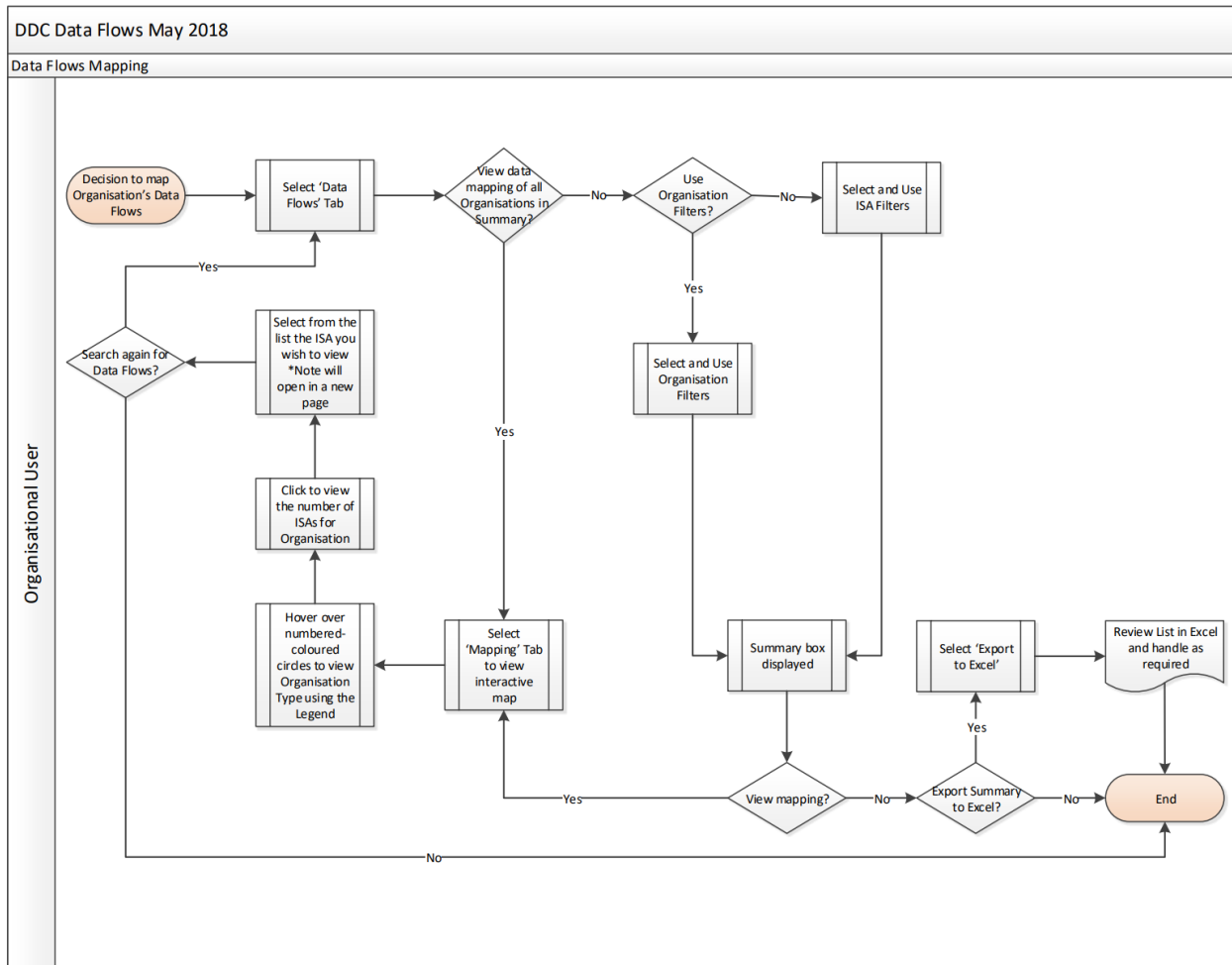

Step	Task	Role(s) responsible
1	Access Data Flow tab	RSU/OSU/AU/VOU
2	Select Organisation	RSU/OSU/AU/VOU
3	Apply Organisation filters	RSU/OSU/AU/VOU
4	Apply ISA filters	RSU/OSU/AU/VOU
5	Select Search	RSU/OSU/AU/VOU
6	Select Mapping Tab	RSU/OSU/AU/VOU
7	Hover over link terminals for further information	RSU/OSU/AU/VOU
8	Select link terminal for Organisation information and ISA link	RSU/OSU/AU/VOU
9	Select ISA link for dashboard ISA information	RSU/OSU/AU/VOU

## **Other Related SOPs**

<Organisation to insert IG related SOPs >

## **References and Related Policies**

<Organisation to insert IG related policies, e.g. Starters & Leavers Policy>

## Abbreviations / Definitions

Abbreviation		Definition
ISA	Information Sharing Agreement	General term used to cover agreements that define the sharing/processing of data/information
DCC	Data Controller Console	An online application used to manage ISAs
RSU	Regional Super User	Provides the Approve/Reject authority for organisations applications
OSU	Organisation Super User	Manage their organisations' application
AU	Active User	DCC user who manage ISAs on a day to day basis
VOU	View Only User	DCC user who may need to view ISA information
ORG/org	Organisation	An individual entity/organisation
DC	Data Controller	A person responsible for controlling/sharing data/information
HST	Host	An entity/organisation that 'owns' the ISA
	Whitelist	A whitelist is a register of entities that are being provided a particular privilege, service. Entities on the list will be accepted, approved and/or recognized. Whitelisting is the reverse of blacklisting, the practice of identifying entities that are denied, unrecognised.
DPC	Data Processing Contracts	Data processing contract is a contract that sets out the legal responsibilities of the organisation being engaged to process the data on behalf of the data controller. This is in line with data protection legislation that requires contracts in place between a data controller and a processor in order to set out the nature of the processing, purposes, duration, types of data etc. Contracts are usually used where there is a financial element to the processing.
DPD	Data Processing Deeds	Data processing deed is similar to a DPC but is used in the event that financial elements are not included in the document. Some organisations use the term Data Processing Agreement instead of Data Processing

		Deed. In either case the document sets out the nature of the processing, purposes, duration, types of data etc..
DPIA	Data Protection Impact Assessment	<p>Data Protection Impact Assessments (DPIAs) help organisations to identify the most effective way to comply with their data protection obligations and meet individuals' expectations of privacy.</p> <p>DPIAs can be an integral part of taking a privacy by design approach.</p> <p>The GDPR sets out the circumstances in which a DPIA must be carried out.</p>
LA	Local Authority	<b>Local government in London</b> takes place in two tiers; a citywide, strategic tier and a <b>local</b> tier. Citywide administration is coordinated by the Greater <b>London Authority</b> (GLA), while <b>local</b> administration is carried out by 33 smaller <b>authorities</b> .
SLA	Service Level Agreements	Service level agreements are used throughout the NHS to list the minimal service requirements and or limits of the service to be provided by one organisation to another. They may be stand alone or sit alongside a service contract. These SLA's may also include directions on what can be done with data.
SC	Service Contracts	A contract for services to be provided by one or more organisation to another/others. An example of this could be a contract between the NHS and a third party when outsourcing services following a successful tendering process. These contracts will usually include a commercial element as well as the data sharing arrangements and as a result be highly commercially sensitive with implications for FOI responses.